



8 Output Control Module

350-214

Publication date 2023-11-29



Table of Contents

1. Technical specifications 8 Output control module	3
1.1. Installation video	3
2. Installation in battery backup	3
3. Short description	4
3.1. Matrix for control	5
3.2. Use the supplied cable	6
4. Connect 8 Output control module to motherboard: CEO3 v2.1	7
5. Connect 8 Output control module to motherboard: CEO3 v5	9
6. Connect 8 Output control module to motherboard: NEO3	10
7. Connect 8 Output control module for motherboard: PRO1 5 A and 10 A	11
8. Connect 8 Output control module for motherboard: PRO1 15 A and 25 A	12
9. Connect 8 Output control module to motherboard: PRO2 v3	13
10. Connect 8 Output control module for motherboards: PRO2 v3 15 A and 25 A	14
11. Connect 8 Output control module to motherboard: PRO3	15
12. If the card lacks a white (JST) contact or if the alarm is to be given via relay switching	16
13. Connection of another 8 Output module	17
14. Technical data - 8 Output control module	18
15. About translation of this document	18
16. Address and contact details	19

1. TECHNICAL SPECIFICATIONS 8 OUTPUT CONTROL MODULE

8 Output control module is a fuse module with 8 fully fused outputs, The card is mounted on nylon brackets. When ordering, check that the card fits the battery backup card to be installed in.

1.1. Installation video

2. INSTALLATION IN BATTERY BACKUP

Mount the card in any card slot in the enclosure, leave plenty of room for cables.

Check that the card fits with the device before mounting. Even if the card fits mechanically, it is not guaranteed to be supported electrically. It is the responsibility of the installer that the card is compatible with battery backup.



NOTE

Install and connect option cards before commissioning battery backup.

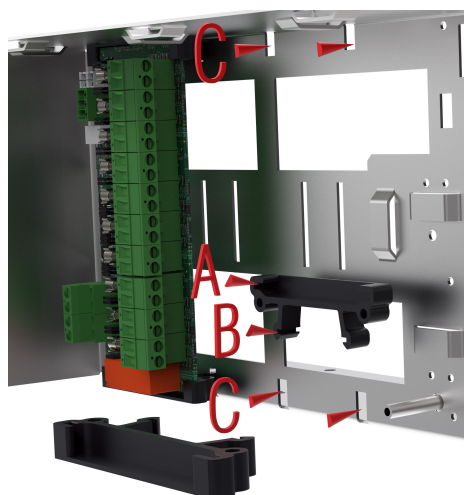

Table 1. Cards are mounted in battery backup

Letter	Explanation
A	The card must sit in the plastic spacers with the connections on the card facing up.
B	Hooks to attach to the plate (C).
C	Snap on plastic spacers.

3. SHORT DESCRIPTION

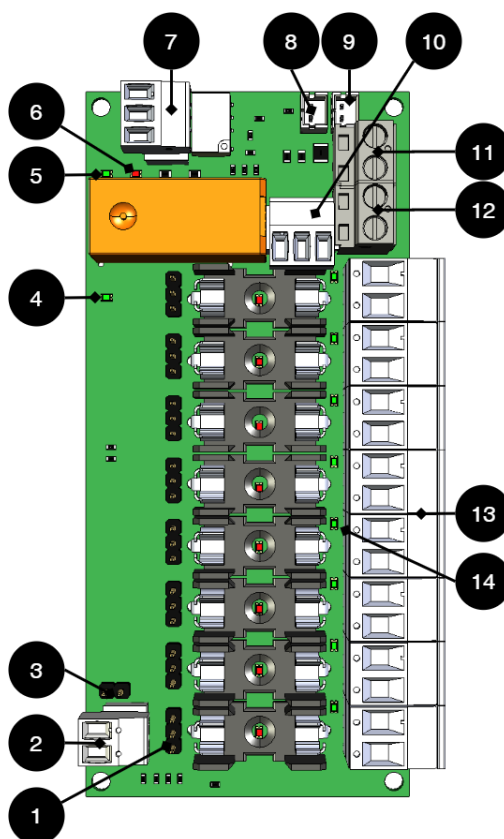



Table 2. Circuit Board Overview - 8 Output control module

No	On circuit board	Explanation
1	JU1-JU8	The jumper of the pin strip controls which function the output (13) has. Control for function: Jumper between 1-2 = Normal function, always on. Jumper between 2-3=Fire alarm control. See also separate table.
2	J9	Fire alarm circuit, must be closed if control is to take place via motherboard. See also separate table.
3	JU9	Master for where control of fire alarms takes place. See also separate table. Unbridged: Control from the card. Bridged: Control from motherboard possible.
4	D21	Green indicator diode=
5	D30	Green indicator diode=
6	D29	Red indicator diode=
7	P4:1-3	Alarm relay, NC, Com NO.
8	J14	Control / alarm cable to motherboard.
9	J15	Forwarding of the control/alarm cable to the next option card.
10	J11	Only used in fire alarm control mode. Jumper between 1-2=Inverted output voltage. Jumper between 2-3=Normal output voltage. See also separate table.
11	P1:3-4	Supply 24 V from motherboard.
12	P1:1-2	Forwarding 24 V power supply to the next option board.
13	P2:1-8	Outputs.
14	D9-D18	Green indicator diode.

3.1. Matrix for control

JU9 Bridged	JU9 Un-settled	JU9 bridged	J9 Un-settled	JU1-8 1-2 Bridged	JU8 2-3 Bridged	Fire control possible	Control via motherboard possible	J11 1-2 bridged	J11 2-3 bridged
X	-	X	-	-	X	X	-	0 V out	24 V out
X	-	-	X	-	X	X	-	24 V out	0 V out
X	-	X	-	X	-	-	-	24 V out	24 V out
X	-	-	X	X	-	-	-	24 V out	24 V out
-	X	X	-	-	X	-	X	24 V out, in case of voltage drop = 0 V out.	24 V out, in case of voltage drop = 0 V out.
-	X	-	X	-	X	-	-	24 V out	0 V out
-	X	X	-	X	-	-	-	24 V out	24 V out
-	X	-	X	X	-	-	-	24 V out	24 V out

X=bridged, - = not bridged. Jumper on J11 controls power supply.



3.2. Use the supplied cable

Use the cable that comes with the box to connect the card.





4. CONNECT 8 OUTPUT CONTROL MODULE TO MOTHERBOARD: CEO3 V2.1

Figure 1. Connect the card as shown in the picture.

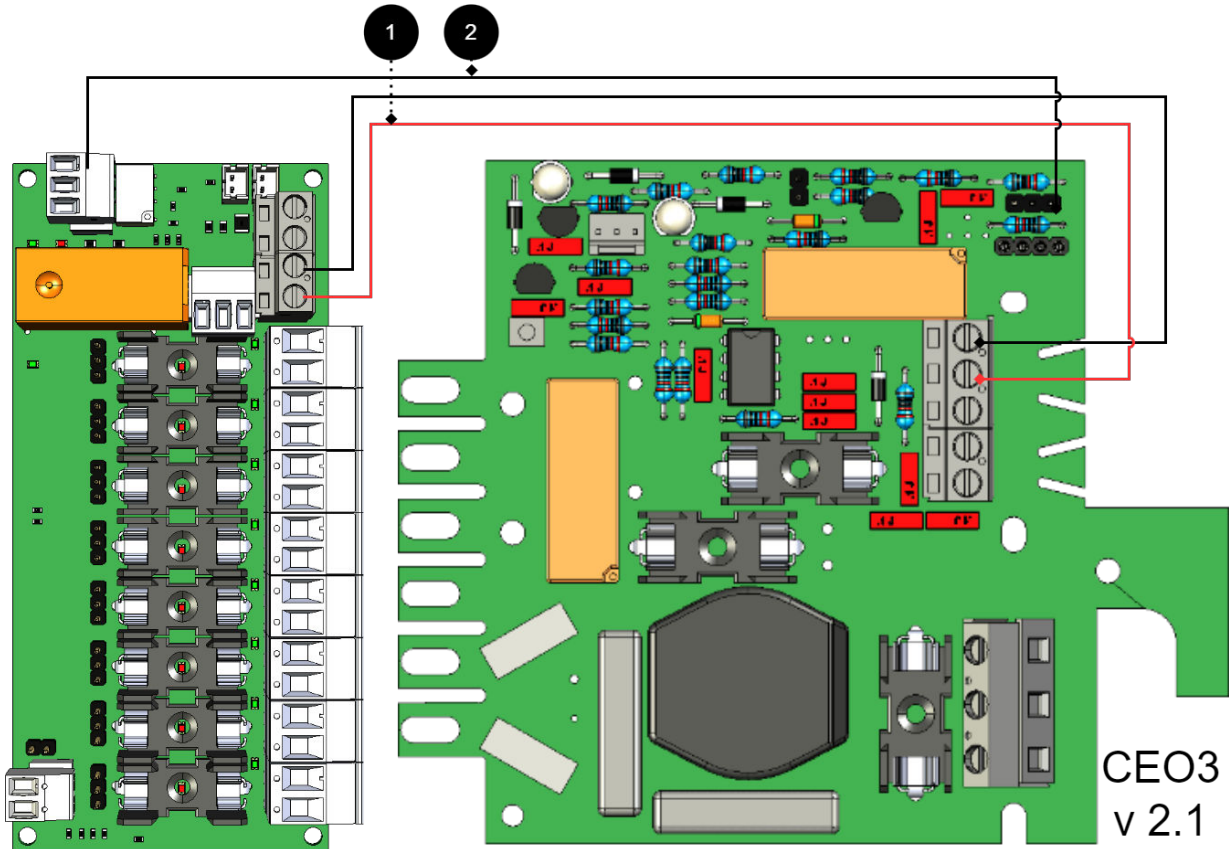

+ and - from load on motherboard are connected to + and - on the option board.

Communication is connected between terminals as the solid line shows.

Connecting the power supply

Connect power (24 V) from the battery backup's load output to the card's 24 V input.

Connection of load

Connect load wiring to P1:1-14 on fuse module for priority load. P1:15-20 for non-priority cargo. (Cards supplied with T2A fuses).



CAUTION

Maximum load is 5 A per load output, and the card's total load must not exceed 16 A.



Table 3. Connections from battery backup to fuse board

No	Connections	8 Output control module	Motherboard
1	Power supply connection:	P1:3-4	Load output 1
2	Alarm output: connected between NO and Com	P3: 1-3 (2-3)	JU3 Connects between the middle pin and an outer pin.
-	Bridging alarms to the card is not possible as the card has no alarm input.	-	-





5. CONNECT 8 OUTPUT CONTROL MODULE TO MOTHERBOARD: CEO3 V5

Figure 2. Connect the card as shown in the picture.

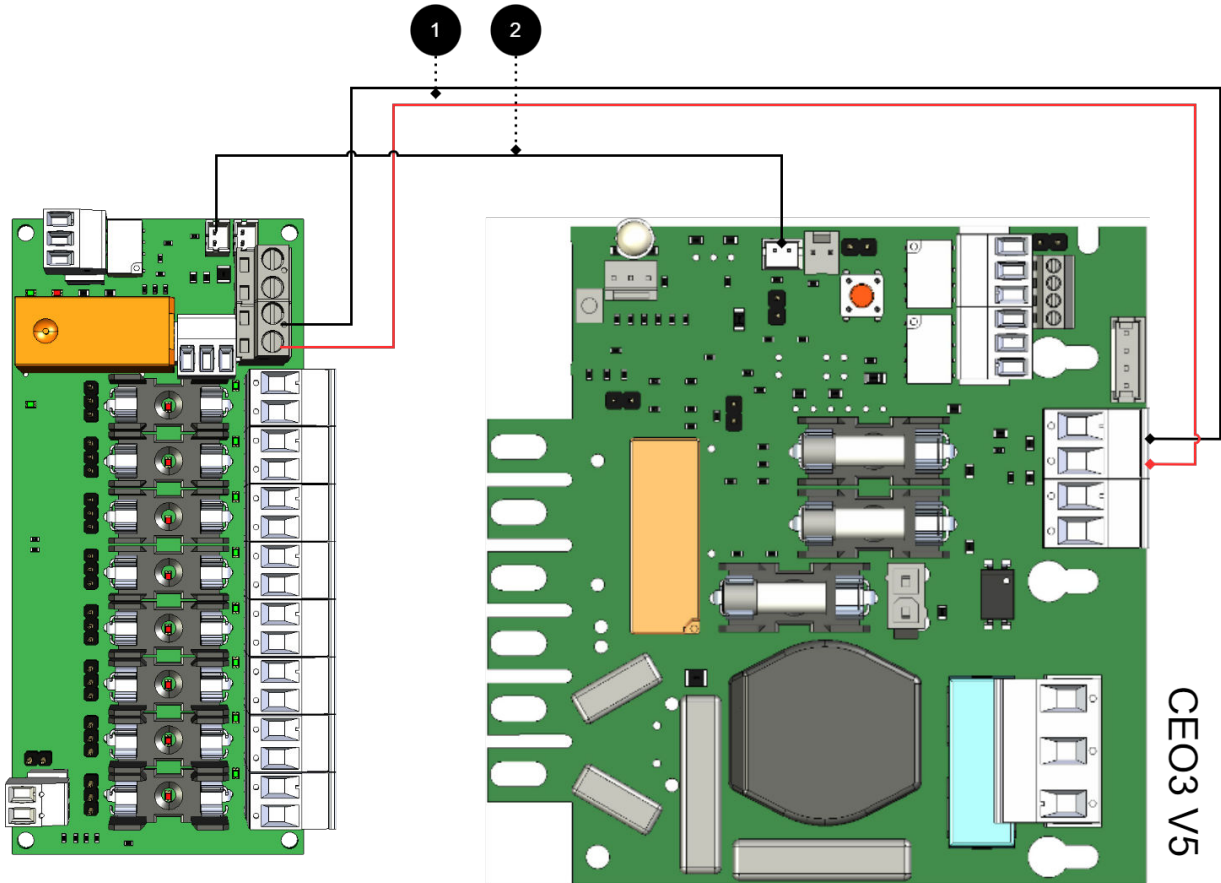

+ and - from load on motherboard are connected to + and - on the option board.

Communication is connected between terminals as the solid line shows.

Connecting the power supply

Connect power (24 V) from the battery backup's load output to the card's 24 V input.

Connection of load

Connect load wiring to P1:1-14 on fuse module for priority load. P1:15-20 for non-priority cargo. (Cards supplied with T2A fuses).



CAUTION

Maximum load is 5 A per load output, and the card's total load must not exceed 16 A.

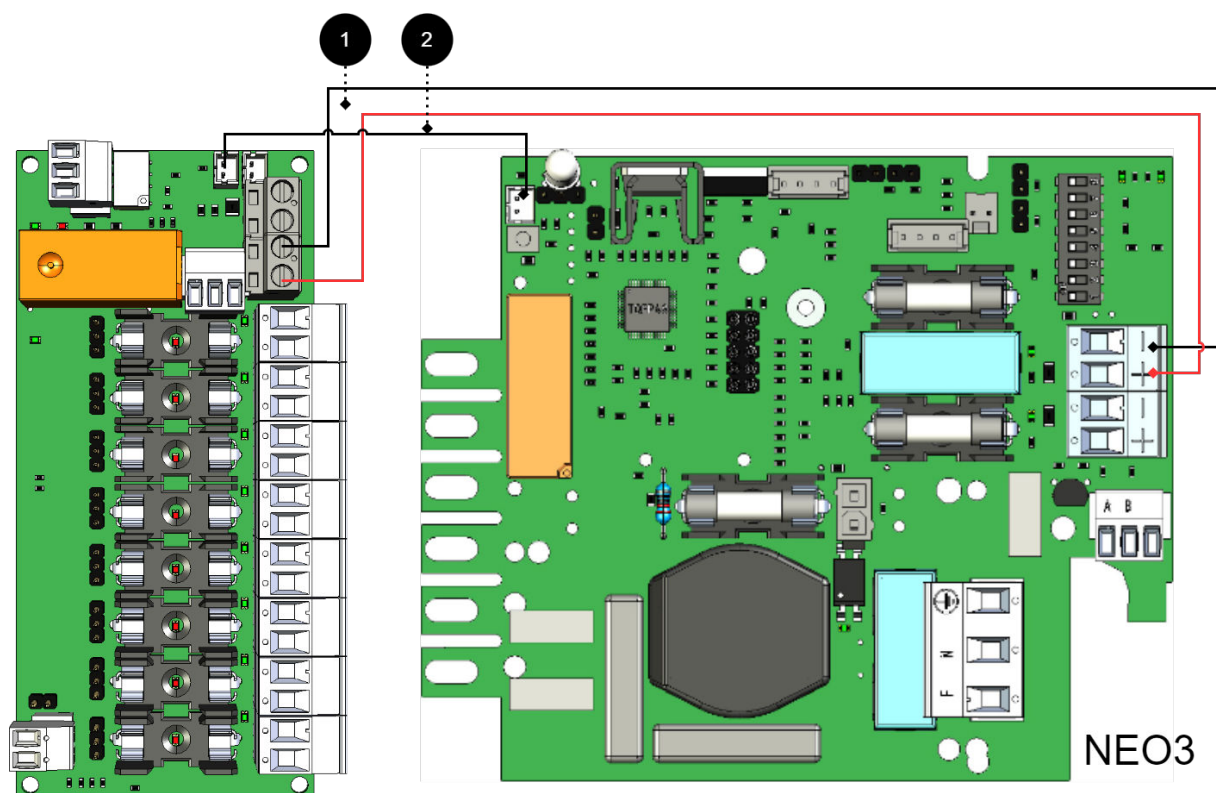

Table 4. Connections from battery backup to fuse board

No	Connections	8 Output control module	Motherboard
1	Power supply connection:	P1:3-4	Load output 2
2	Bridging alarm to motherboard: Bridging of alarms to additional option cards	J14 J15	J27

6. CONNECT 8 OUTPUT CONTROL MODULE TO MOTHERBOARD: NEO3

Figure 3. Connect the card as shown in the picture.



+ and - from load on motherboard are connected to + and - on the option board.

Communication is connected between terminals as the solid line shows.

Table 5. Connections from battery backup to fuse board

No	Connections	8 Output control module	Motherboard
1	Power supply connection:	P1:3-4	Load output 2
2	Bridging alarm to motherboard: Bridging of alarms to/from additional option cards	J14 J15	J5





7. CONNECT 8 OUTPUT CONTROL MODULE FOR MOTHERBOARD: PRO1 5 A AND 10 A

Figure 4. Connect the card as shown in the picture.

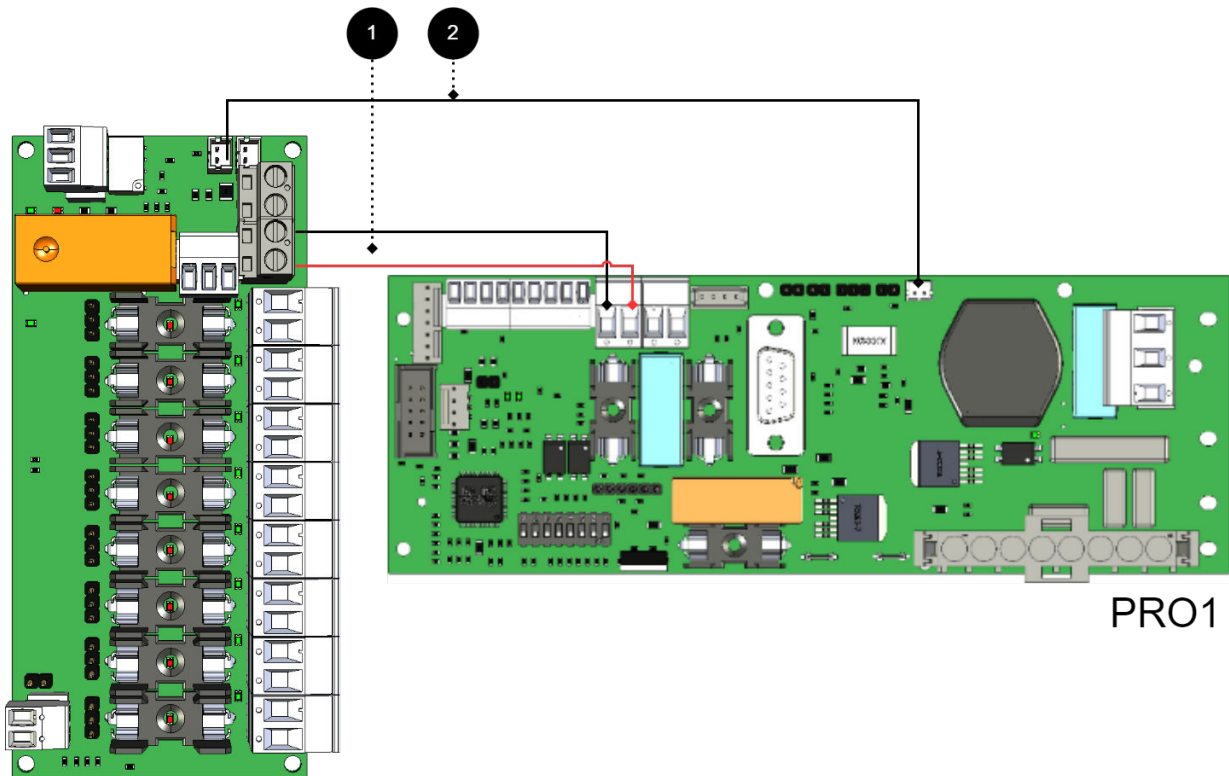

+ and - from load on motherboard are connected to + and - on the option board.

Communication is connected between terminals as the solid line shows.

Table 6. Connections from battery backup to fuse board

No	Connections	8 Output control module	Motherboard
1	Power supply connection:	P1:3-4	Load output 1
2	Bridging alarm to motherboard:	J14	J13
	Bridging alarms to/from additional option cards:	J15	-



8. CONNECT 8 OUTPUT CONTROL MODULE FOR MOTHERBOARD: PRO1 15 A AND 25 A

Figure 5. Connect the card as shown in the picture.

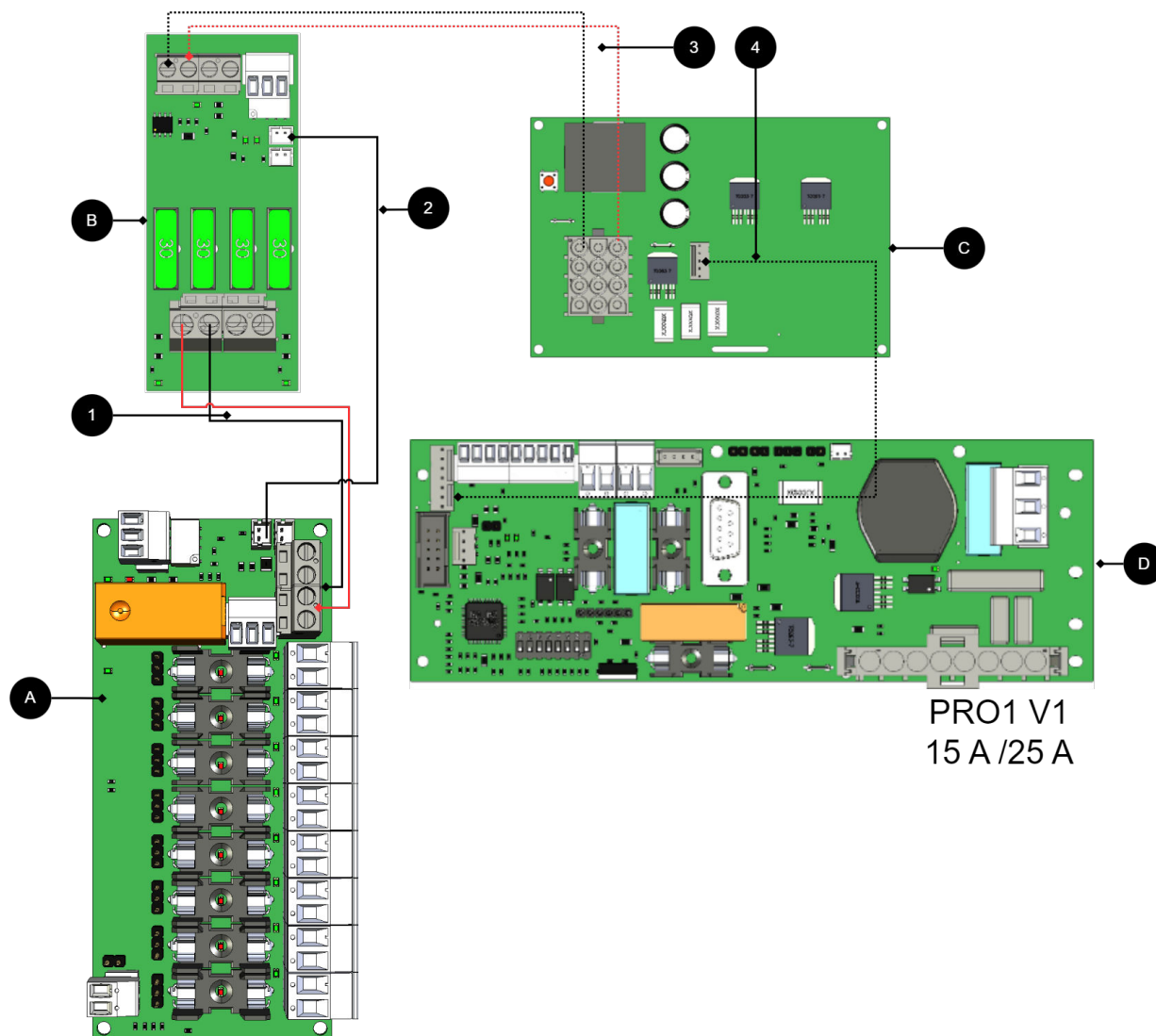

+ and - from load on motherboard are connected to + and - on the option board.

Communication is connected between terminals as the solid line shows.

Table 7. Connections 15 A and 25 A units

No/letter	On circuit board (A)	Explanation
A	8 Output modules	Optional location.
B	2 Output module	Card for connection of load and power supply to 8 Output control module.
C	Effect card	Available in 15 A and 25 A units.
D	PRO1	Motherboard in battery backup.
1	P1:3-4	Connect power supply 8 Output control module from (B).
2	J14	Alarms are connected to load card.
3, 4	-	Internal power supply and communication between cards.





9. CONNECT 8 OUTPUT CONTROL MODULE TO MOTHERBOARD: PRO2 V3

Figure 6. Connect the card as shown in the picture.

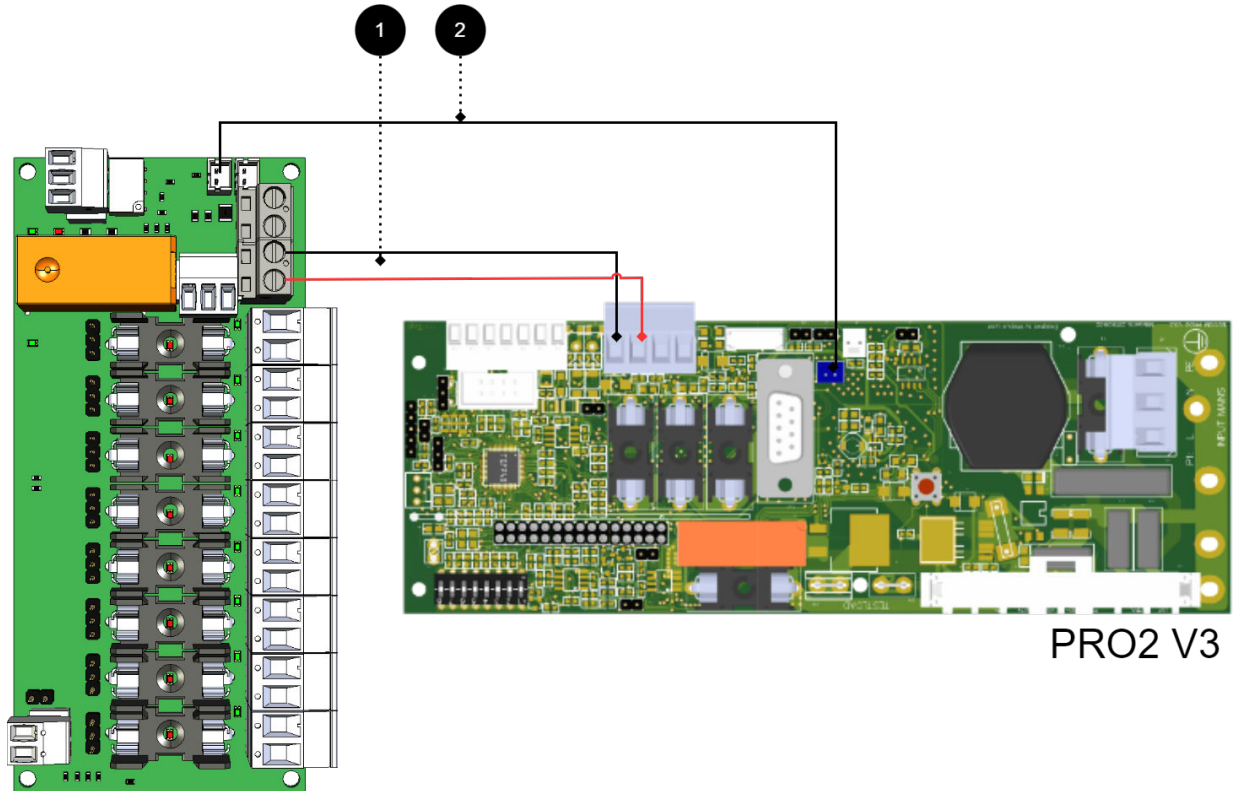

+ and - from load on motherboard are connected to + and - on the option board.

Communication is connected between terminals as the solid line shows.

Table 8. Connections from battery backup to fuse board

No	Connections	8 Output control module	Motherboard
1	Power supply connection:	P1:3-4	Load output 1
2	Bridging alarm to motherboard:	J14	J1
	Bridging alarms to additional option cards:	J15	



10. CONNECT 8 OUTPUT CONTROL MODULE FOR MOTHERBOARDS: PRO2 V3 15 A AND 25 A

Figure 7. Connect the card as shown in the picture.

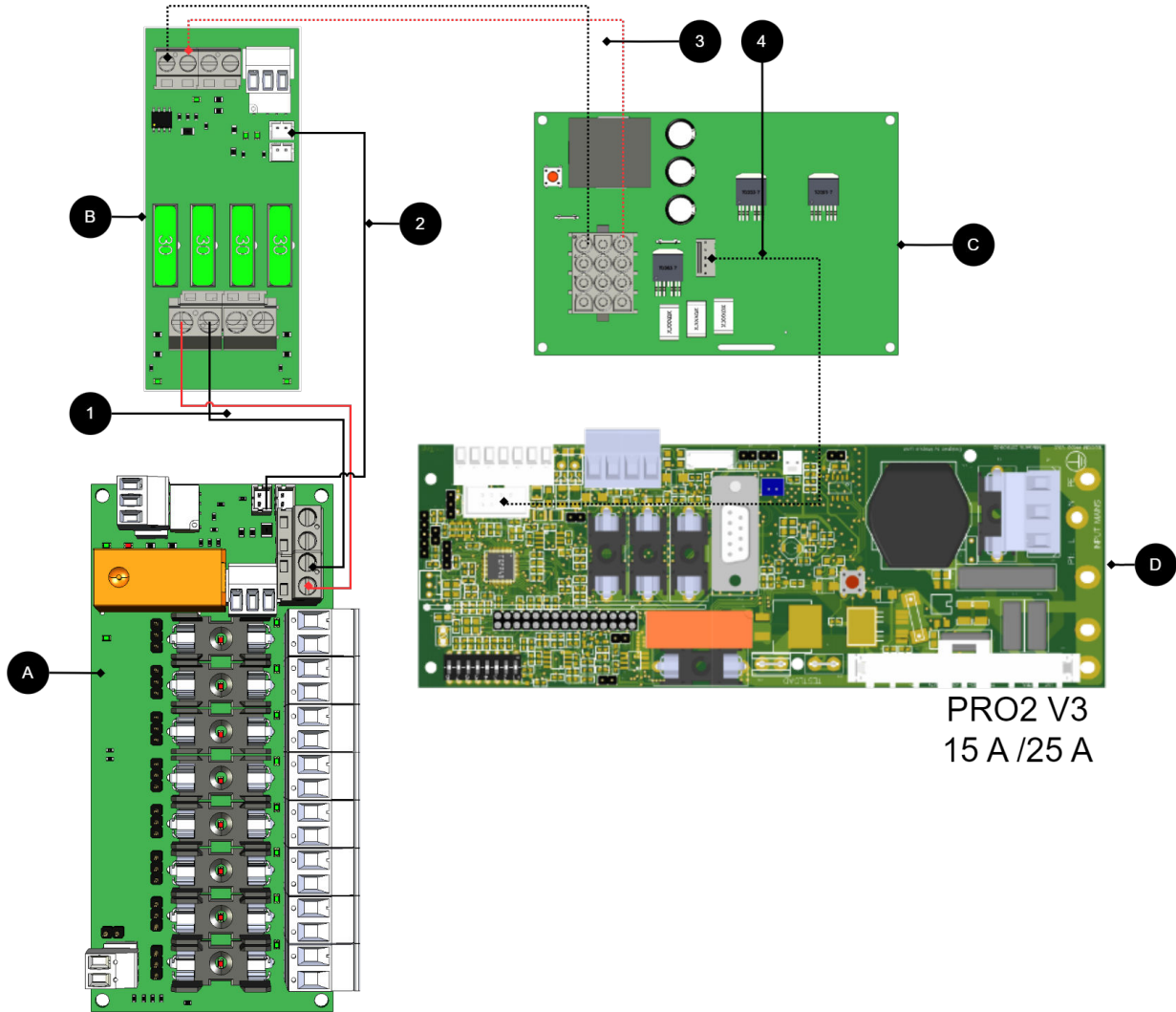

PRO2 V3
15 A / 25 A

+ and - from load on motherboard are connected to + and - on the option board.

Communication is connected between terminals as the solid line shows.

Table 9. Connections 15 A and 25 A units

No/letter	On circuit board (A)	Explanation
A	8 Output control module	Optional location.
B	2 Output module	Card for connection of load and power supply to 8 Output control module.
C	Effect card	Available in 15 A and 25 A units.
D	PRO2 v3	Motherboard in battery backup.
1	P1:3-4	Disconnect power supply 8 Output control module (B).
2	J14	Connect alarm to load card.
3, 4	-	Internal power supply and communication between cards.





11. CONNECT 8 OUTPUT CONTROL MODULE TO MOTHERBOARD: PRO3

Figure 8. Connect the card as shown in the picture.

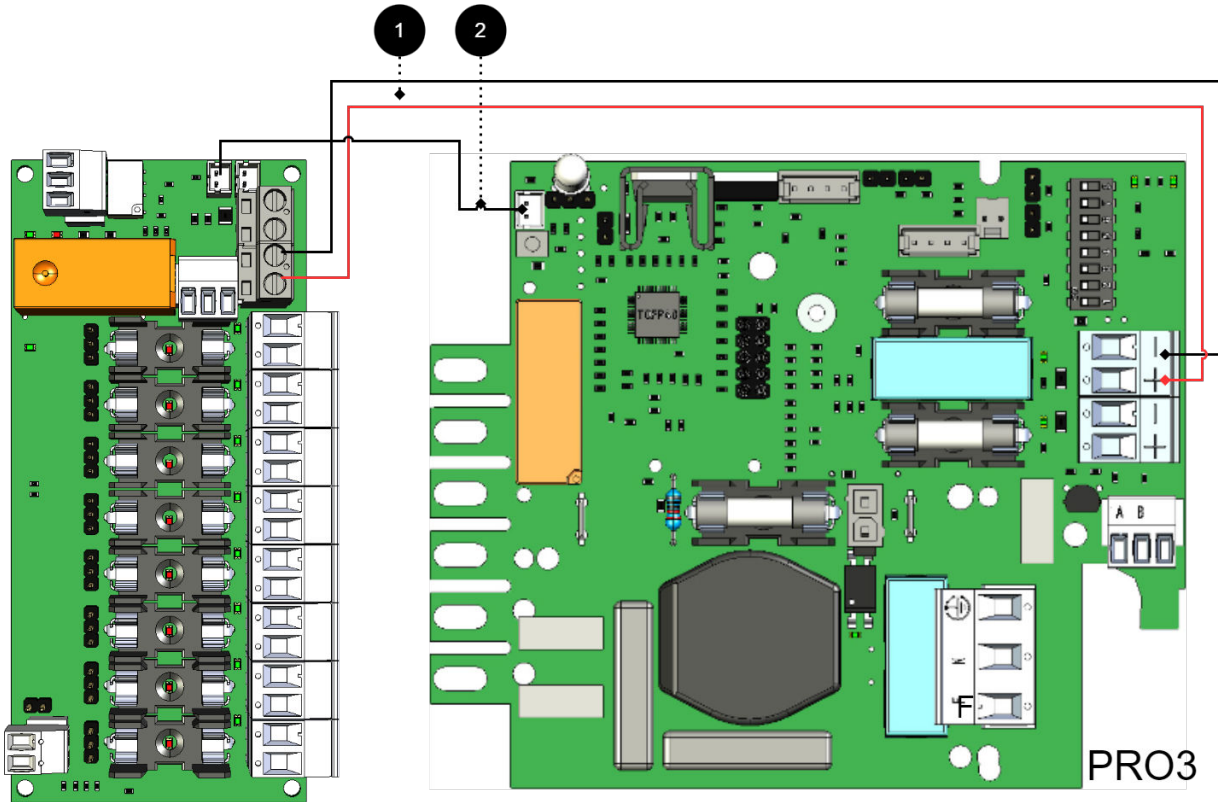

+ and - from load on motherboard are connected to + and - on the option board.

Communication is connected between terminals as the solid line shows.

Table 10. Connections from battery backup to fuse board

No	Connections	8 Output control module	Motherboard
1	Power supply connection:	IN 12 V / 24 V	Load output 2
2	Bridging alarm to motherboard:	J11	J5



12. IF THE CARD LACKS A WHITE (JST) CONTACT OR IF THE ALARM IS TO BE GIVEN VIA RELAY SWITCHING

Figure 9. Connect the card as shown in the picture.

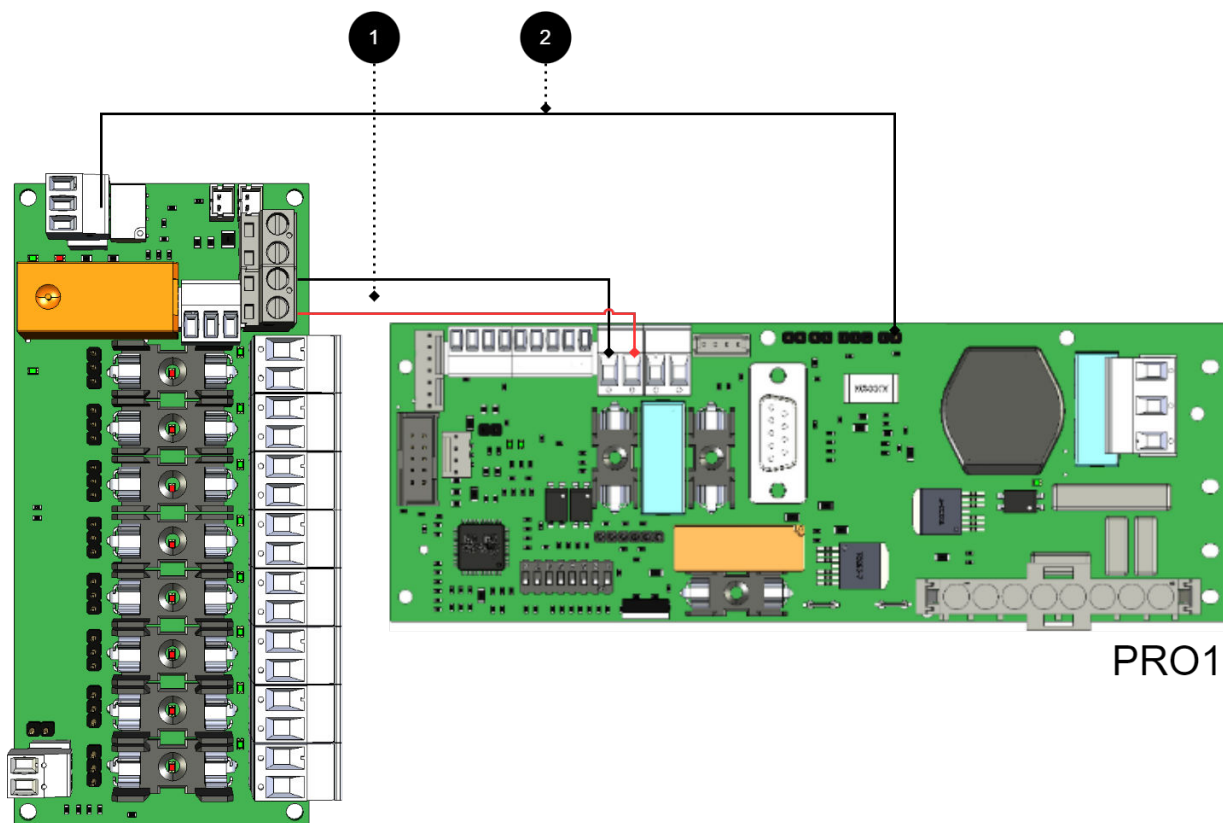

Older cards¹ which lacks a JST contact, then the alarm is connected via relay switching. P3:1-3

Table 11. Connections from battery backup to fuse board

No	Connections	10 Output module	Motherboard
1	Power supply connection:	IN 12 V / 24 V	Load output 1
2	Alarm output:	P3:1-3	J13

¹Early versions of PRO1 and PRO2 may lack white terminal (JST).





13. CONNECTION OF ANOTHER 8 OUTPUT MODULE

Figure 10. Connecting additional option cards to the motherboard

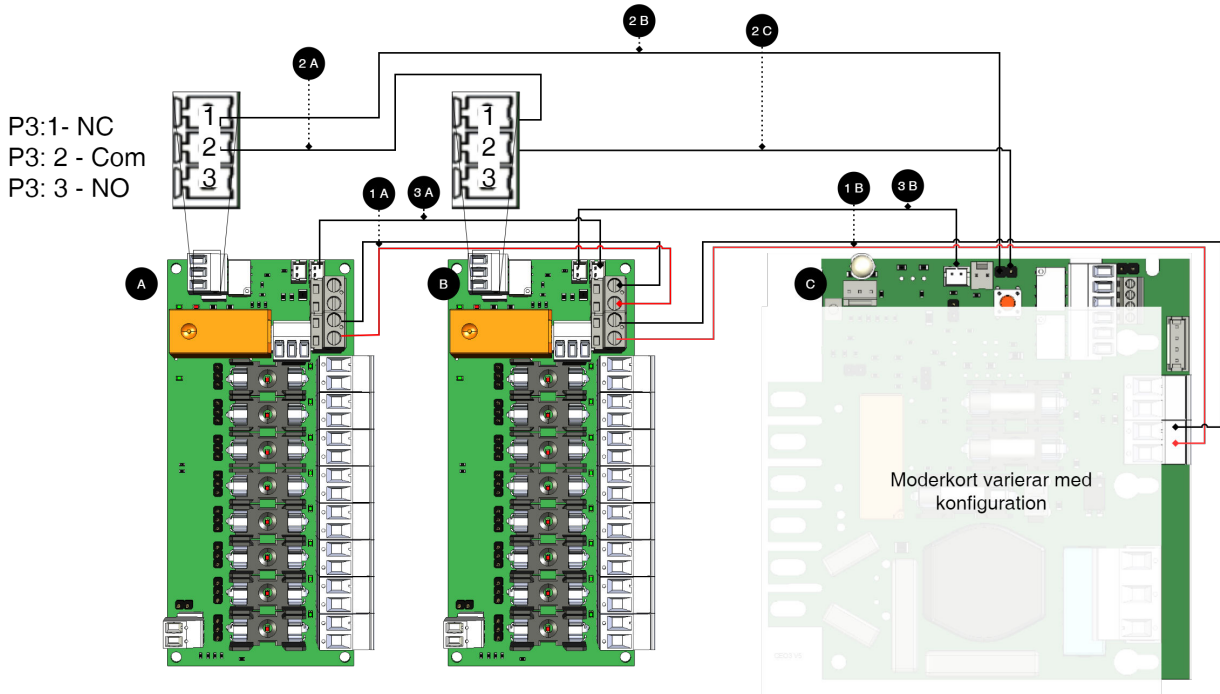

NOTE

For alarm connection use 2A and 2B for connection of newer devices (after approx. 2018). For older devices (before approx. 2018) use 3A-3C.

Table 12. Connection of additional option cards

Letter / No	Explanation	On the card
A	8 Output control module.	-
B	8 Output control module.	-
C	Motherboard, may vary with configuration.	-
1 A	Power supply to 1B from 1A.	P1:1-+2
1 B	Power supply to 1B from motherboard.	P1:3-4
2 A	Bridging of alarms to card B.	J15
2 B	Connection of alarm on C (motherboard) from board A.	See table below.
2C	Connection of alarm on C (motherboard) from board B.	See table below.
3 A	Alarm output switches on C (motherboard).	P3:1-3
3 B	Alarm output is connected to C (motherboard).	P3:1-3

Table 13. Alarms from optional cards are connected on terminal block (on motherboard)

Motherboard	Terminal as an alarm from an optional card must be connected (on motherboard)
CEO3 v5	J27



Motherboard	Terminal as an alarm from an optional card must be connected (on motherboard)
NEO3	J5
PRO1	J13
PRO2 v3	J1
PRO3	J5

14. TECHNICAL DATA - 8 OUTPUT CONTROL MODULE

Info	Explanation
Card name:	8 Output control module
Product description	8 Output control module is a protection module with 10 fully protected outputs, of which seven are prioritized and three are non-prioritized.
The product fits in	Battery backups with motherboard: PRO1, PRO2, PRO2 V3, PRO3 and NEO3.
Measure	120 x 45 mm.
Own consumption	65mA
Output voltage	24 V
Fuses	F2A comes with cards.
Indication	Yes, LED on circuit board

Table 14. Outputs

Info	Value
Alarm outputs, number	1
Alarm on changing relay? (Yes No)	Yes
Load outputs, number	8
Voltage on load output	27.3V DC
Voltage limit, upper, on load output	27.9V DC
Voltage limit, lower, on load output. With battery operation and disconnected mains voltage.	20V DC
Priority (always voltage) load outputs (Yes/No)	Yes
Max load, per output	10 A
Maximum load, total, (must not be exceeded).	16 A
Load output plus (+) fused? (Yes No)	Yes
Load output minus (-) secured (Yes/No)	No
Fuses on output	T2A.
Connection to buzzer? (Yes No)	No

Manufactured in Milleteknik's factory in Partille, Sweden.

This translation is not verified and should be cross referenced with the swedish original before use.

15. ABOUT TRANSLATION OF THIS DOCUMENT

User manual and other documents are in the original language in Swedish. Other languages are machine translated and not reviewed, errors may occur.





16. ADDRESS AND CONTACT DETAILS

Milleteknik AB
Ögärdesvägen 8 B
S-433 30 Partille
Sweden
+46 31 340 02 30
info@milleteknik.se
www.milleteknik.com



This page is intentionally left blank.